

PRODUCT NUMBER
91269-XXXXLF

PLATING

- 0 = 0.2µm GOLD/GXT
- 1 = 0.76µm GOLD/GXT
- 3 = 0.38µm GOLD/GXT

UNDERPLATING 1.27µm Ni MIN

WHEN REQUIRED, ADD SUFFIX LETTER "LF"
INDICATES THE PRODUCT IS RoHS
COMPATIBLE, SEE NOTE 6 & 7

PACKAGING TYPE, NOTE 3

TOTAL NB OF POSITIONS, 3 TO 17

NOTES:

- 1 - HOUSING MAT'L : HIGH TEMPERATURE THERMOPLASTIC. UL94V-0 COLOR: CREAM
- 2 - PIN MATERIAL : COPPER ALLOY
- 3 - PACKAGING
= POLYBAGS
TR = TAPE & REEL (SEE TA845 FOR PRODUCT AVAILABILITY)
- 4 - 7N MIN RETENTION IN EITHER DIRECTION
- 5 - TO DETERMINE DIMENSIONS :
N = NUMBER OF POSITIONS
EXAMPLE : 8 POS N x 2.0 = 16.0mm
- 6 - 91269-XXXXLF IS SIMILAR TO 91269-XXXX, THE SUFFIX "LF" IS ADDED FOR EASY LEAD FREE IDENTIFICATION
- 7 - RoHS COMPATIBLE PRODUCT SPECIFICATIONS
 - a - MANUFACTURING PROCESS COMPATIBILITY
- THE HOUSING WILL WITHSTAND EXPOSURE TO 260°C ±5°C SOLDER BATH TEMPERATURE FOR 5 SECONDS IN A WAVE SOLDER APPLICATION WITH A 1.6mm MIN THICK CIRCUIT BOARD.
 - b - LABELLING:
- MEETS PACKAGING SPECS AS PER GS-14-920
 - c - THIS PRODUCT MEETS EUROPEAN DIRECTIVES AND OTHER COUNTRY REGULATIONS AS DISCRIBED IN GS-22-008.
- 8 - HOLE DIMENSION TO BE $\phi 1.6 \pm 0.03$ FOR INTERFERENCE FIT APPLICATIONS.
HOLE DIMENSIONS TO BE $\phi 1.95 \pm 0.05$ FOR LOCATION APPLICATION WITH AUTOMATIC PICK AND PLACE MACHINES.
- 9 - RECOMMENDED IR PROFILE PER TA842.
- 10 - ODD NB OF POS = 7.0
EVEN NB OS POS = 5.0

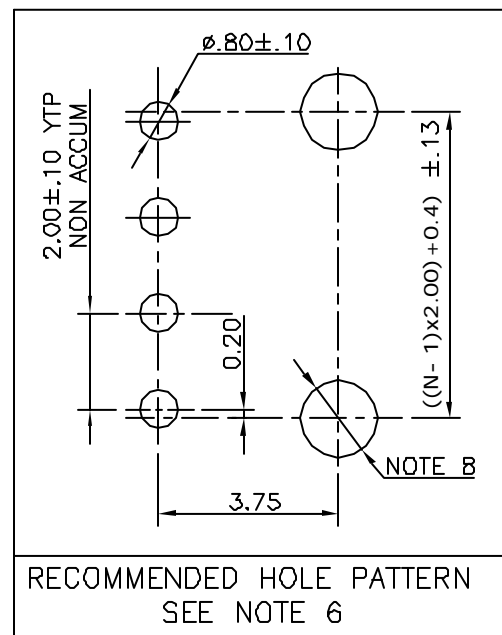
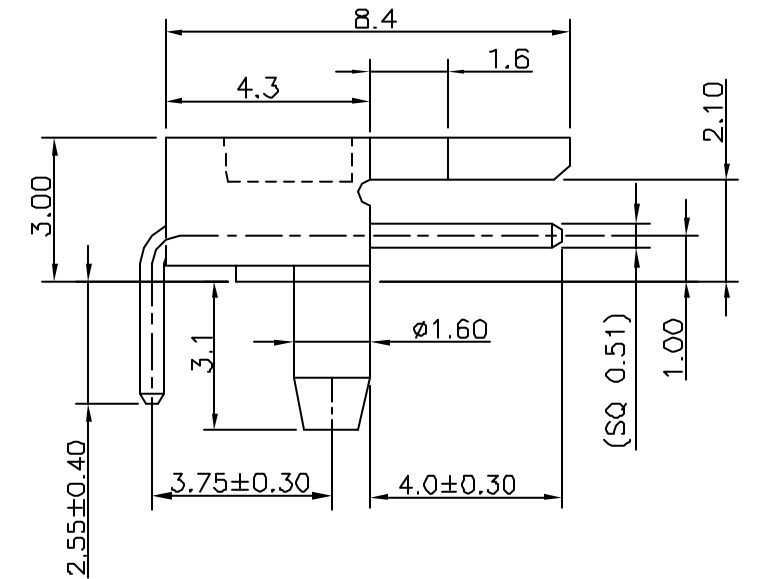
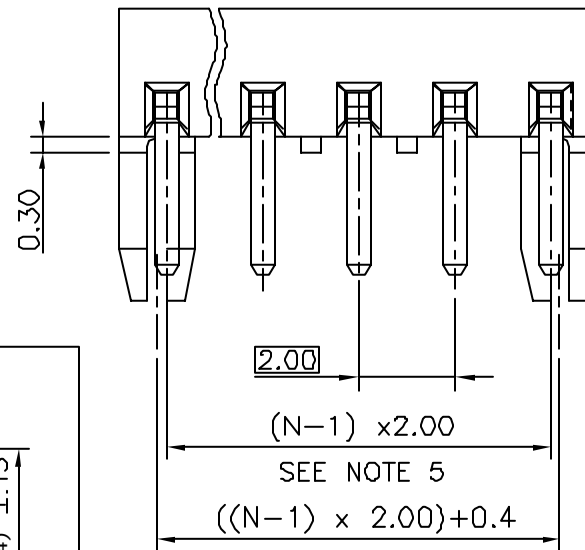
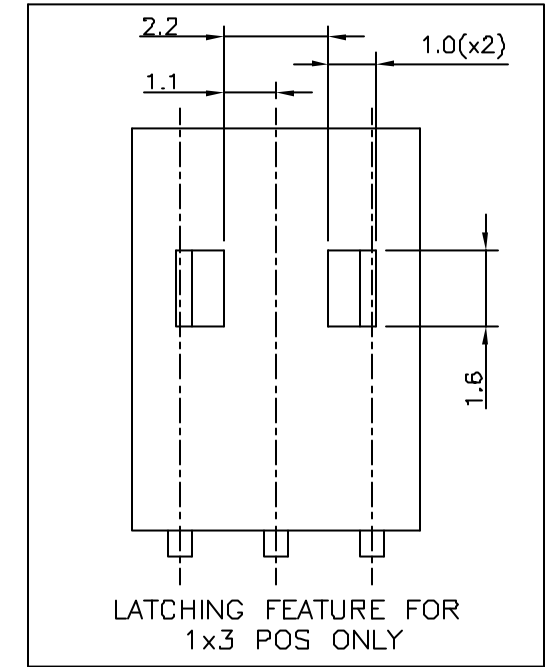
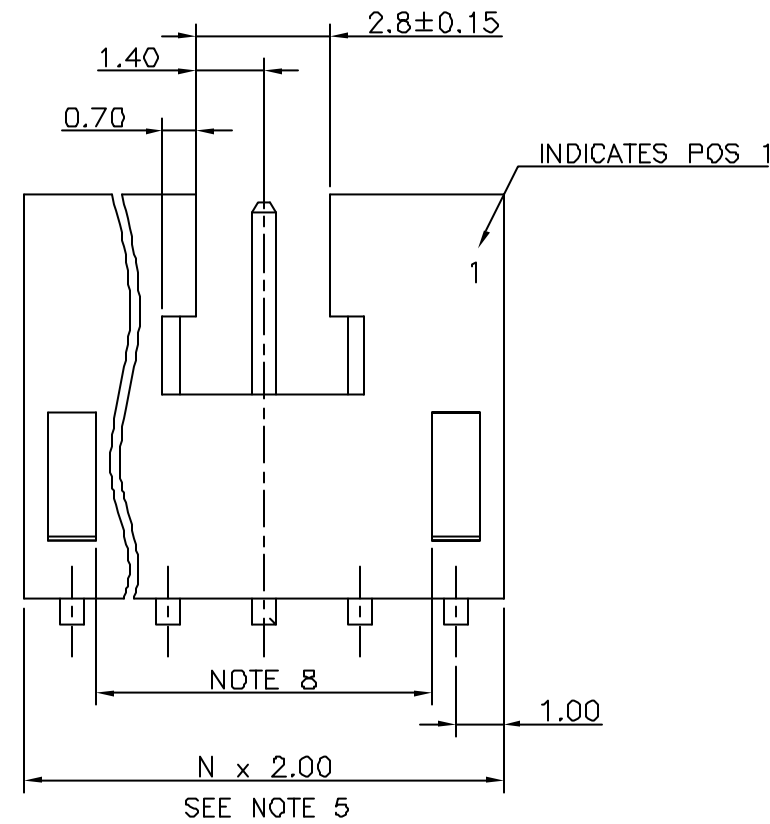

mat'l. code		surface		tolerance		projection		product family	
SEE TABLE		ISO 1302		ISO 406 ISO		101		MINITEK	
ltr	ecn na dr date	tolerances unless otherwise specified		.X ±0.3		mm		title	
D	C20044 MSC 92.03.01	angles		.XX ±0.13		scale 5:1		MINITEK, TMT, SR	
E	F10390 LMU 01.08.06	Linear		.XXX ±0.05				RA, POL & LATCHING	
F	F03067 LMU 03.18.03	±2'						dwg no	
G	F05-0128 LMU 05.02.21	dr		L.MULIN 01.08.06				sheet 1 of 1	
H	F06-0210 LMU 06.07.04	engr		J.COMPAGNON 01.08.06				size	
J	F08-0145 ELA 17.04.08	chr		P.NIZZI 01.08.06				91269	
		appd		JM.C 01.08.06				A3	
sheet index		revision sheet						type	
								CUSTOMER Drawing	



Copyright FCI